

SPECIFICATIONS

Body Material: High impact thermoplastic alloy blend  
 Colors: Green, Black, Silver & Yellow  
 To specify color add G for green, B for black,  
 S for silver or Y for yellow in "X" position in part number.  
 Melt Temperature: 500°F (260°C)  
 High temperature dimensional stability.  
 Chemical resistance to gasoline and oils.  
 Weather resistant.  
 UV stable.  
 High impact strength at temperatures down to -40°F (-40°C).  
 Bearing Material: Black Nylon  
 Maximum Temperature: 170°F (77°C)  
 Maximum Intermittent Temperature: 355°F (179°C)  
 Low coefficient of friction.  
 Chemical resistant.  
 Good abrasion resistance.  
 High strength.  
 Button Material: 303 Stainless  
 Actuating Force: 3 ±1 lbs.  
 Actuating Stroke: .25"  
 Switch:  
 Piezo driven solid state switch.  
 Operating Temperature: -40°F to 221°F (-40°C to 105°C)  
 Operating Voltage: 8-36V AC or DC  
 Max Current: .3A fused (auto resetting)  
 Typical Life: Greater than 20 million operations.

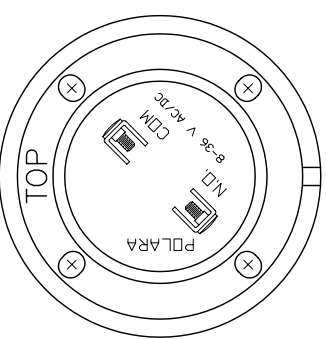

INFORMATION ON THIS DOCUMENT IS NOT TO BE USED TO REPRODUCE OR DISCLOSED IN WHOLE OR IN PART WITHOUT WRITTEN CONSENT OF POLARA

10-0-05	C	22294	BB							
Revised - 10/20/05										
02-28-02	B	21827	BB	CLM	LB	WR	FB	RVC	JMC	
09-13-01	A	21776	BB	CLM	LB	WR	FB	RVC	JMC	
REV. DATE	LTR	E.C.O. NO.	BY	CKR	ENG	DSN	MFG	QA	FNL	

**POLARA ENGINEERING INC.**  
 4115 W. ARTESIA AVE. FULLERTON, CA. 92833

TOLERANCES: .XXX ±.005 .XX ±.02 (EXCEPT AS NOTED) SCALE 1:2

DRAWN BY	BB	CKR.	CLM	ENG. MGR.	LB	MFG. MGR.	FB	SHEET	1	OF	1
DATE	08-05-99	DSN.	WR	Q.A. APP.	RVC	FINAL APP.	JMC	USE			

TITLE: MOVING PUSH BUTTON w/ SS CAP DWG. NO. MPBS-X