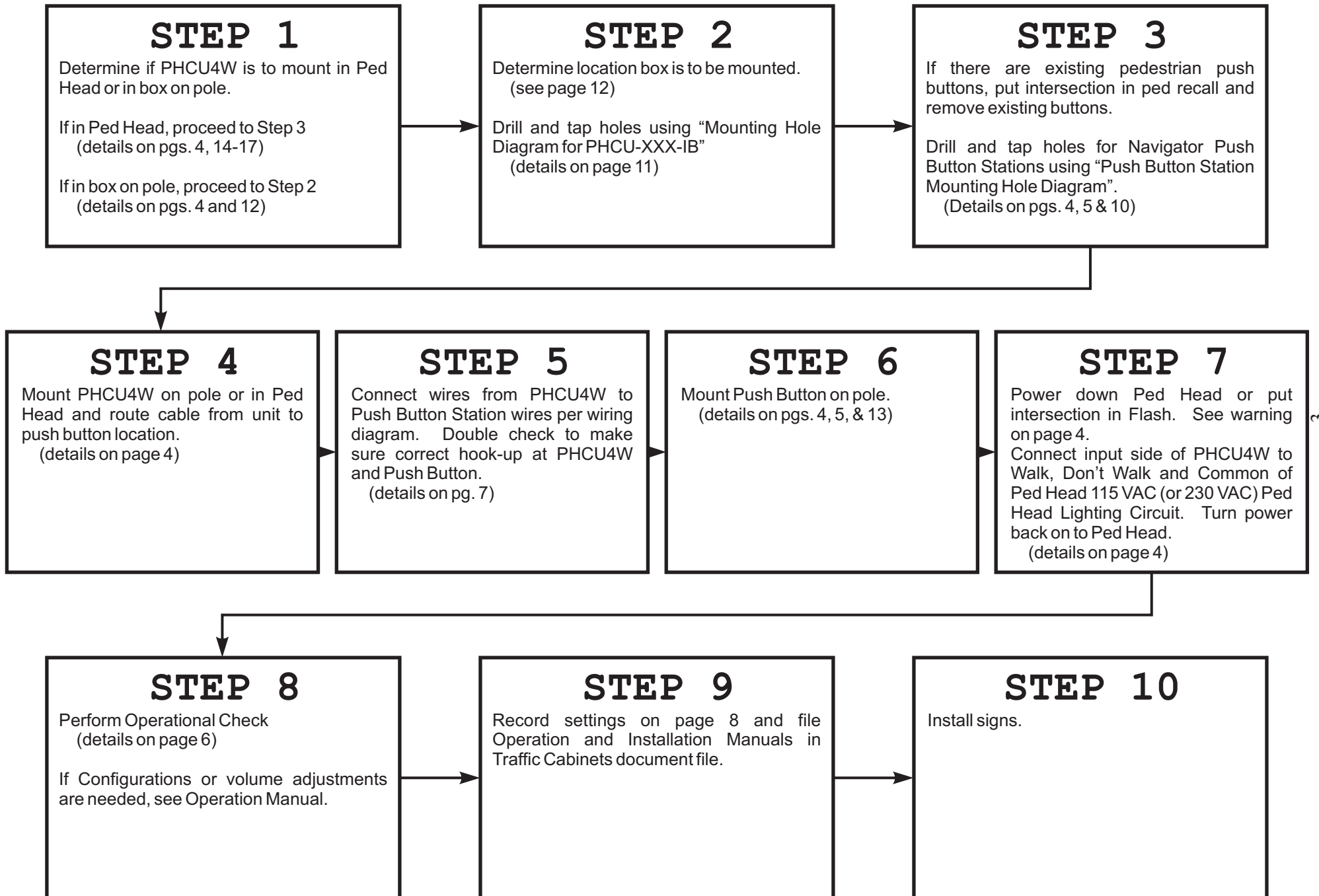



**Table of Contents**

	<b>Page</b>
<b>System Installation</b> .....	<b>1</b>
Overview .....	1
Summary of Installation Steps .....	3
Installation .....	4
Installing Control Units .....	4
Installing Push Button Stations on Poles .....	4
Wood/Concrete Pole Mount .....	5
<b>System Operational Check</b> .....	<b>6</b>
<b>4 Wire Navigator Wiring Diagram</b> .....	<b>7</b>
<b>Default and Field Settings</b> .....	<b>8</b>
<b>PBS Mounting Hole Diagram</b> .....	<b>10</b>
<b>PHCU4W-XXX-IB Mounting Hole Diagram</b> .....	<b>11</b>
<b>PHCU4W-XXX-IB Installation</b> .....	<b>12</b>
<b>Wire Routing Instructions</b> .....	<b>13</b>
<b>Changing Control Chip and Voice Chip in the Field</b> .....	<b>14</b>
<b>Pictures for Mounting PHCU4W in PED Heads</b> .....	<b>15</b>

# Summary of Installation Steps



## Installation

### INSTALLING CONTROL UNITS

See diagrams/photos later in this manual for typical mounting. If mounting in a ped head, mount PHCU4W in each ped head using the provided mounting brackets and hardware (see pages 15-18). If mounting in box on pole, see mounting template on page 11 and diagram on page 12.

Refer to the wiring diagram on page 7. Route 4 wire cable between the PBS and PHCU4W, then connect to output side of PHCU4W. Double check for correct hookups.

**Install Push Button Station(s) per below before performing next step.**

**WARNING:** The following WALK and DON'T WALK wiring connections are made to AC line voltage and is dangerous. It is recommended that the intersection be placed in flash or turn off PED signals while connections to these signals are made. Refer to the wiring diagram on page 7 and connect ped sign, Common, Walk, and Don't Walk to input side of PHCU4W (additional ground is optional).

Return the traffic signal controller or ped heads to normal operation.

Test the system for proper operation. Check each PBS per the Operational Check on page 6.

### INSTALLING PUSH BUTTON STATIONS ON POLES

Determine if Navigator PBS's have special messages. If the messages are provided by Polara, there will be a label on the back with the street names. Determine location for each per the street being crossed.

The recommended button height from the ground to the center of the push button is 39" maximum. It can be lower, but should not be higher.

**Note:** The visually impaired use the face of the push button station and the arrow on the button to determine the direction of travel. The arrow should point across the street in the direction of travel and, when mounted, the sign of the PBS should be parallel with the crosswalk. You can tell the unit is mounted correctly by placing the outside of your forearm against the sign (or front of the unit) with your fingers straight. Your arm should be parallel to the crosswalk and point to where the crosswalk ends across the street.

Place Intersection in ped recall.

Remove existing push buttons from poles.

Remove the sign from each PBS by removing the 4 screws holding the sign. If the arrow direction is correct there is no need to open the unit. If the arrow needs to be changed or the voice chip changed, remove the 6 cover screws and carefully bring the cover to approximately 60° which frees the bottom hinge, then remove the cover. Place the cover on a flat surface with the backside facing you. Loosen the four screws, then slowly press on the front of the button and turn the button diaphragm counter-clockwise. The button diaphragm assembly should pop out. Orient the arrow in the proper direction. Place the diaphragm so the corner of each tab goes under each of the 4 screws. Push and turn the button diaphragm until it snaps into each cavity with the corner of each tab under the screws then tighten the screws. Reinstall cover and six screws. **Be careful not to drop the cover and break the hinge. Also keep it away from metal pole or other metal objects. The magnet may pull the diaphragm assembly out and possibly damage it if it comes too close to other metal objects.**

Note: Template is on page 10 to assist with orienting the following holes.

Hold the PBS against the pole in the proper orientation (as described earlier) and mark on the pole for the two mounting holes (these are on 6" centers). Drill and tap them to ¼-20 thread.

Approximately 3 3/8" (3.44") below the bottom ¼-20 hole a wire hole is needed. If a push button frame was on the pole this hole may already exist. If a hole does not exist, drill a 5/8" minimum diameter hole.

**Do not drill with Push Button Station open near pole. Magnets on speaker and button will attract shavings potentially causing problems.**

See exhibit at on page 13 before performing following step. Slide rubber boot over 4 wire cable (and button wires if present). Connect button wires to terminals (if present). (Do not use crimp on forks, they interfere with the rubber boot.) Bend wires 90° to unit. Apply silicone to boot edge, then press boot into round cavity on back of PBS so that bellows portion collapses inward. Apply tape to wires then onto boot so boot is held firmly to the wires in this position. Make sure wires are well taped and sealed so water cannot follow wires into boot and terminal block area.

Bolt PBS to pole using two ¼-20 bolts and washers provided. Tighten until secure on pole.

Connect the four wires of the PBS cable to the four wires routed to the PHCU4W (observing correct hookup) and splice them together using the Polara supplied silicone filled butt connectors.

Now go back to "Installing Control Unit" section and finish electrical connections.

#### WOOD/CONCRETE POLE MOUNT

If the PBS is going to be mounted on a wooden pole, mounting diagrams are available for download at <http://www.polara.com/assistance.htm> (or click on support button on main page). You can also contact Polara for more information.

## System Operational Check

Following installation and power up of units, check the following:

1. The pole unit should start playing the locate tone within about 5 seconds of power up. This assumes the unit is in DON'T WALK mode.
2. Push each PBS and verify that the red LED above the push button turns on with the first push, and that a tick is heard for each push. If button wires to the traffic controller exist, verify that the PED call is transmitted to the traffic signal controller.
3. Following a button push, verify that a walk message is heard and the push button vibrates during the next walk cycle.
4. Confirm the proper sound plays during clearance. If unit is set for countdown, during the first clearance cycle after power up, the unit should be silent. During the second or later cycle, the pole unit should play a voice countdown of the seconds remaining to end of clearance.
5. Proceed to Configuration in Operations Manual. Once all units are configured as desired, recheck each unit for a full cycle to ensure all options and features operate as desired.

When you are satisfied that all units are working properly, install sign on each PBS.

Evaluate sound levels and responsiveness to ambient noise.

Using the Configurator, make any volume adjustments as needed to each PBS.

# 4 WIRE NAVIGATOR WIRING DIAGRAM

For control units installed in ped heads, the installer provides these wires. Colors are optional. For PHCU4W-XXX-IB and/or if control unit is provided in box by Polara, this is Cable #2 and the colors must be connected as shown.

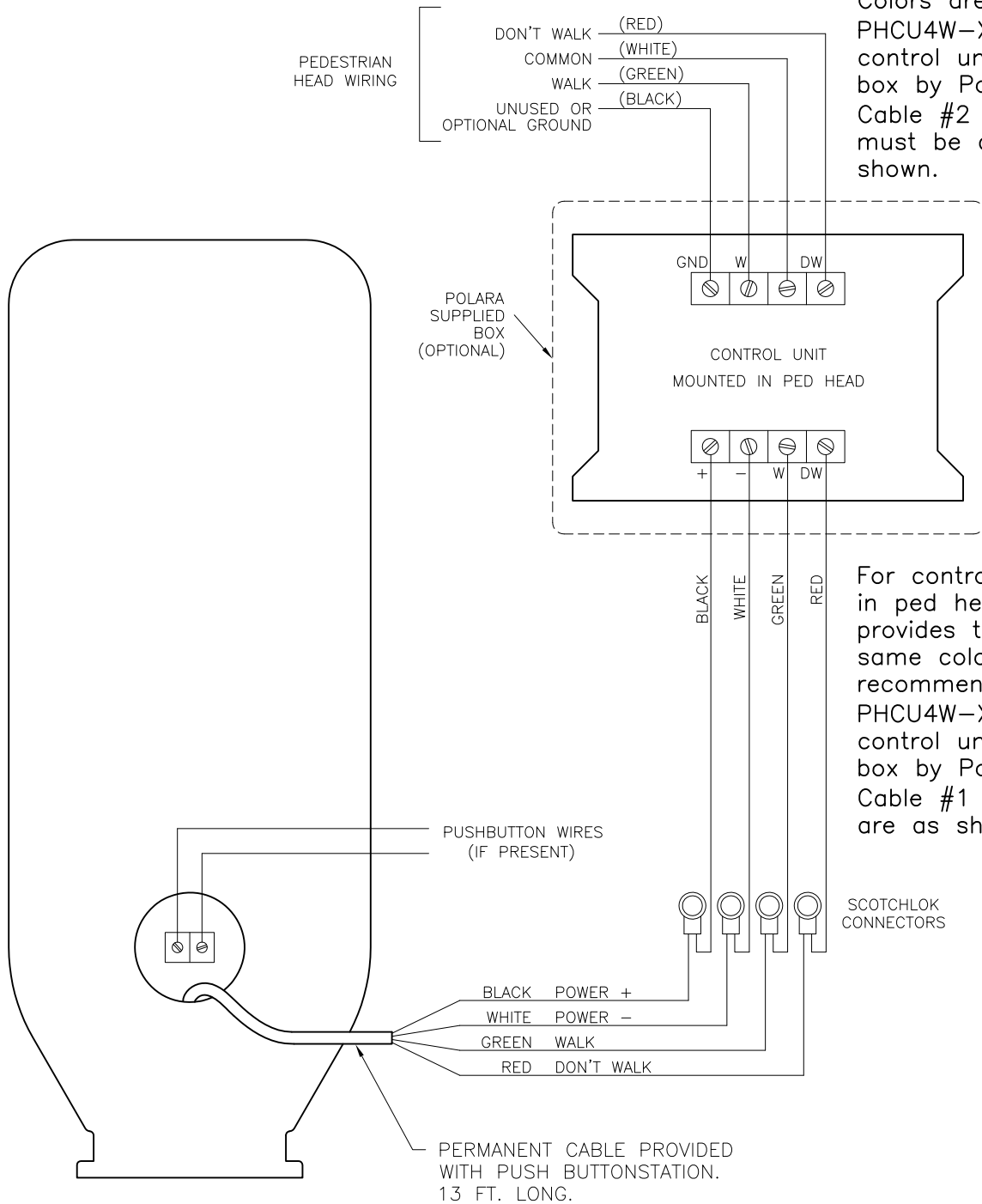

For control units installed in ped heads, the installer provides these wires. The same colors are recommended. For PHCU4W-XXX-IB and/or if control unit is provided in box by Polara, this is Cable #1 and the colors are as shown.

## Default and Field Settings

City \_\_\_\_\_ State/Province \_\_\_\_\_ Install Date \_\_\_\_\_

Intersection: \_\_\_\_\_

Street: \_\_\_\_\_

Corner: \_\_\_\_\_

ID: \_\_\_\_\_

Phase: \_\_\_\_\_

Defaults (Effective with Configurator v1.12, Nav2 v1.17 and Nav4 v1.15)

LOCATE VOL MIN	10%	_____
LOCATE VOL MAX	50%	_____
INFO MSG VOL MIN	60%	_____
STD WALK VOL MIN	40%	_____
STD WALK VOL MAX	70%	_____
EXT WALK VOL MIN	70%	_____
EXT WALK VOL MAX	80%	_____
VOL OVER AMBIENT	0 dB	_____
WALK MODE SOUND	STD MSG	_____
WALK SOUND PAUSE	.5 SEC	_____
WALK SOUND TRIG	ANY PUSH	_____
SOUND/VIB TIMER	FULL WALK	_____
SOUND/VIB RETRIG	BTN PUSH	_____
CANCEL ON CLEARANCE	YES	_____
CLEAR MODE SOUND	TONE 1	_____
CLEAR TONE PAUSE	1 SEC	_____
LOCATE SOUND	TONE 1	_____
LOCATE TONE TIME	1 SEC	_____
PLEASE WAIT MSG	NO	_____
DIRECTION MSG	NORTH	_____
INFO MESSAGE	NONE	_____
CANCEL ON WALK	YES	_____
EXT PUSH TIME	1.0 SEC	_____
SECOND LANGUAGE	NO	_____
THIRD LANGUAGE	NO	_____
EXT PUSH PRIORITY	NO	_____
WALK PING PONG	NO	_____
CLEAR PING PONG	NO	_____

Special Notes: \_\_\_\_\_

\_\_\_\_\_  
 \_\_\_\_\_  
 \_\_\_\_\_



## Default and Field Settings (page 2 for islands)

ID: \_\_\_\_\_

Phase: \_\_\_\_\_

Defaults

LOCATE VOL MIN	10%	_____	_____	_____	_____
LOCATE VOL MAX	50%	_____	_____	_____	_____
INFO MSG VOL MIN	60%	_____	_____	_____	_____
STD WALK VOL MIN	40%	_____	_____	_____	_____
STD WALK VOL MAX	70%	_____	_____	_____	_____
EXT WALK VOL MIN	70%	_____	_____	_____	_____
EXT WALK VOL MAX	80%	_____	_____	_____	_____
VOL OVER AMBIENT	0 dB	_____	_____	_____	_____
WALK MODE SOUND	STD MSG	_____	_____	_____	_____
WALK SOUND PAUSE	.5 SEC	_____	_____	_____	_____
WALK SOUND TRIG	ANY PUSH	_____	_____	_____	_____
SOUND/VIB TIMER	FULL WALK	_____	_____	_____	_____
SOUND/VIB RETRIG	BTN PUSH	_____	_____	_____	_____
CANCEL ON CLEARANCE	YES	_____	_____	_____	_____
CLEAR MODE SOUND	TONE 1	_____	_____	_____	_____
CLEAR TONE PAUSE	1 SEC	_____	_____	_____	_____
LOCATE SOUND	TONE 1	_____	_____	_____	_____
LOCATE TONE TIME	1 SEC	_____	_____	_____	_____
PLEASE WAIT MSG	NO	_____	_____	_____	_____
DIRECTION MSG	NORTH	_____	_____	_____	_____
INFO MESSAGE	NONE	_____	_____	_____	_____
CANCEL ON WALK	YES	_____	_____	_____	_____
EXT PUSH TIME	1.0 SEC	_____	_____	_____	_____
SECOND LANGUAGE	NO	_____	_____	_____	_____
THIRD LANGUAGE	NO	_____	_____	_____	_____
EXT PUSH PRIORITY	NO	_____	_____	_____	_____
WALK PING PONG	NO	_____	_____	_____	_____
CLEAR PING PONG	NO	_____	_____	_____	_____

Special Notes: \_\_\_\_\_

\_\_\_\_\_

\_\_\_\_\_

\_\_\_\_\_

\_\_\_\_\_

\_\_\_\_\_

\_\_\_\_\_

# MOUNTING HOLE DIAGRAM FOR PUSH BUTTON STATION

When printing document in Adobe Acrobat, be sure that "None" is selected in Print Scaling in the printing dialog box to ensure that document is printed to the correct scale. Otherwise, recreate template using dimensions shown.

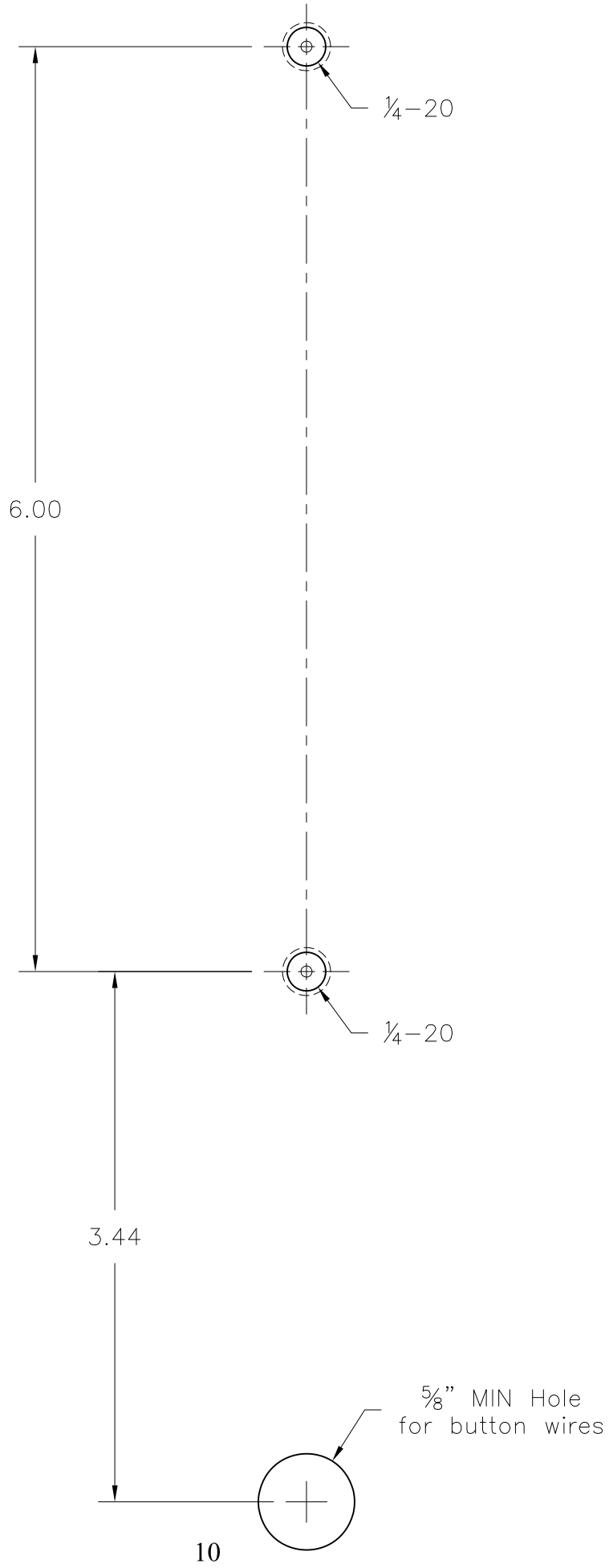

**MOUNTING HOLE DIAGRAM  
FOR POLARA PROVIDED PHCU4W-XXX-IB**

When printing document in Adobe Acrobat, be sure that "None" is selected in Print Scaling in the printing dialog box to ensure that document is printed to the correct scale. Otherwise, recreate template using dimensions shown.

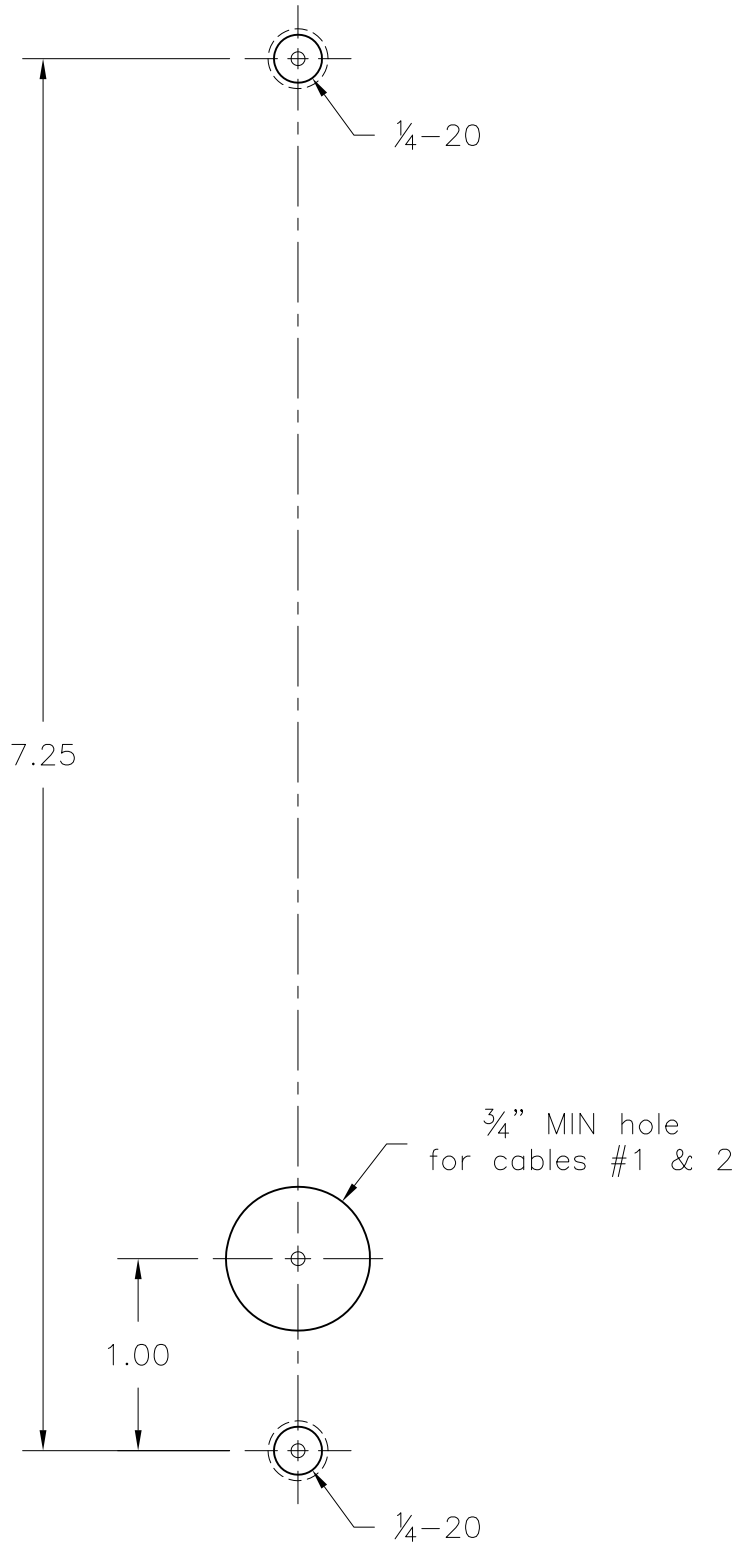

# PHCU4W-XXX-IB INSTALLATION (CUTAWAY VIEW)

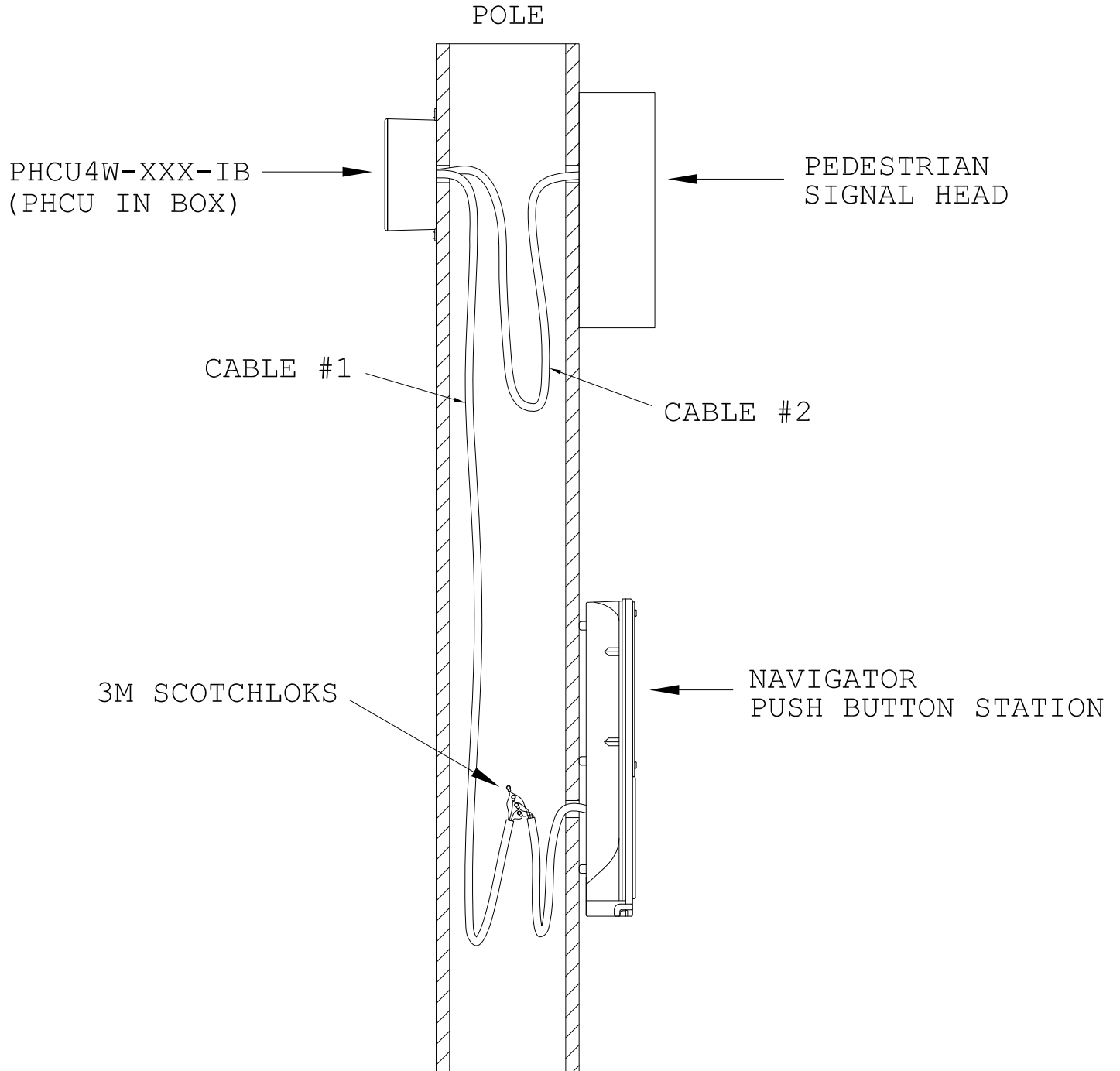

# WIRE ROUTING INSTRUCTIONS

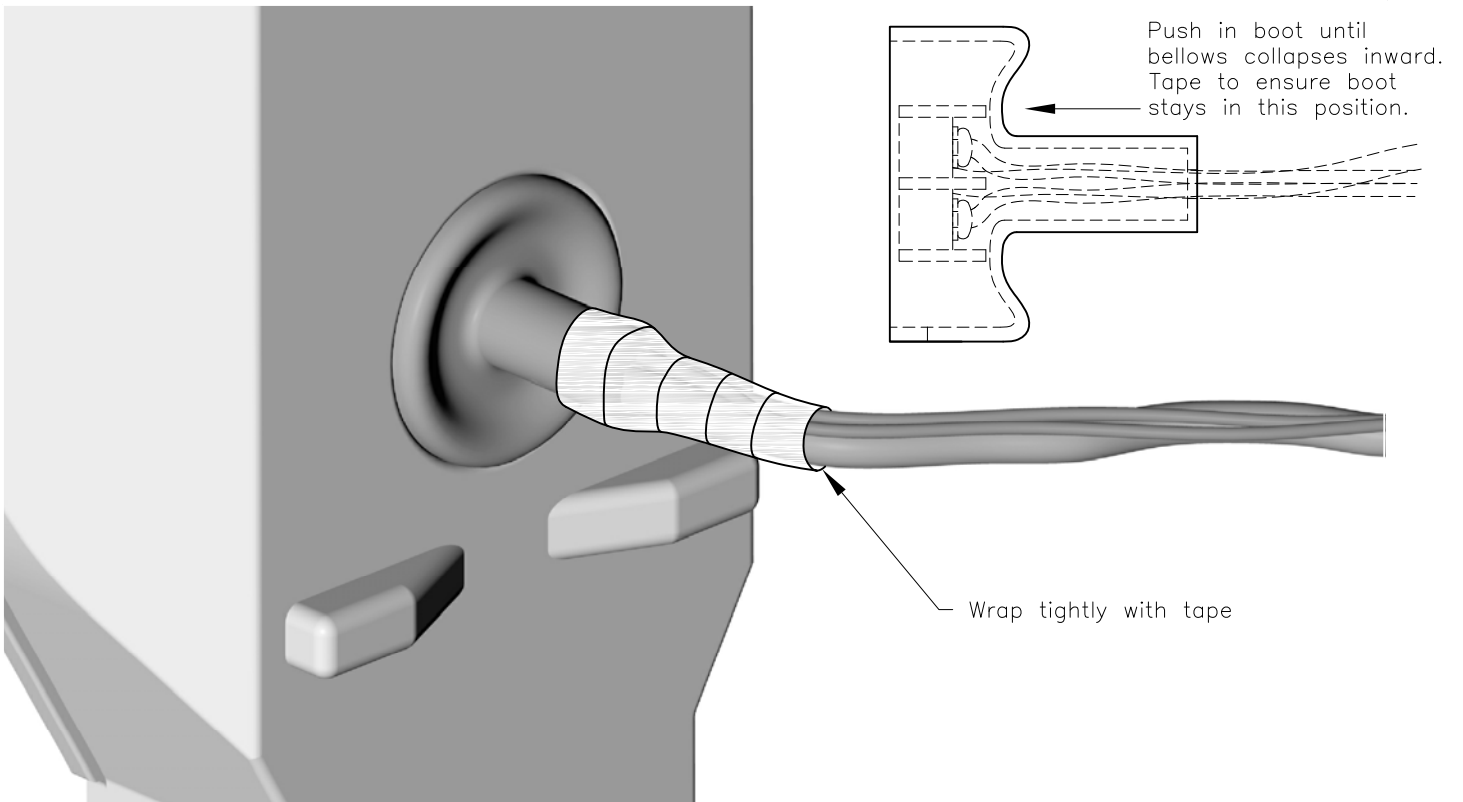
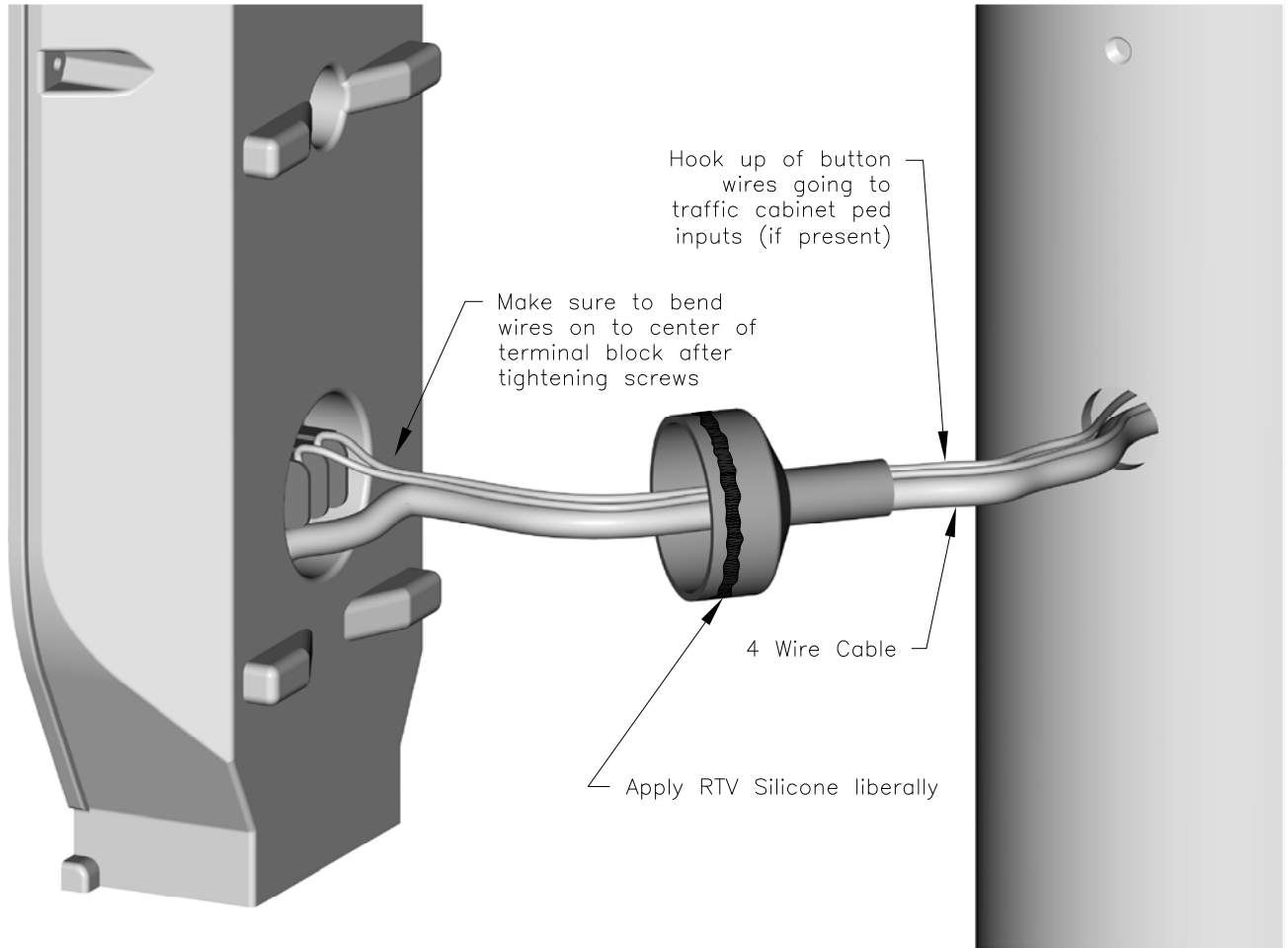

# Changing Control Chip and Voice Chip in the Field

**Before changing either chip, power down the unit.**

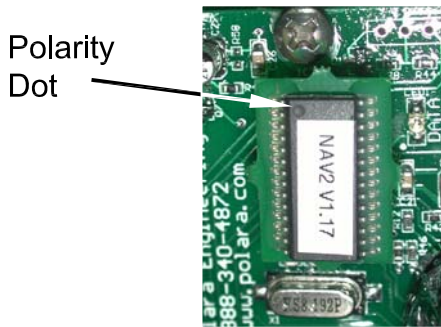

## Control Chip:

To remove, pull chip directly out.

To replace, align connector on control chip with header on PCB and make sure polarity dot on chip is towards the top as shown.

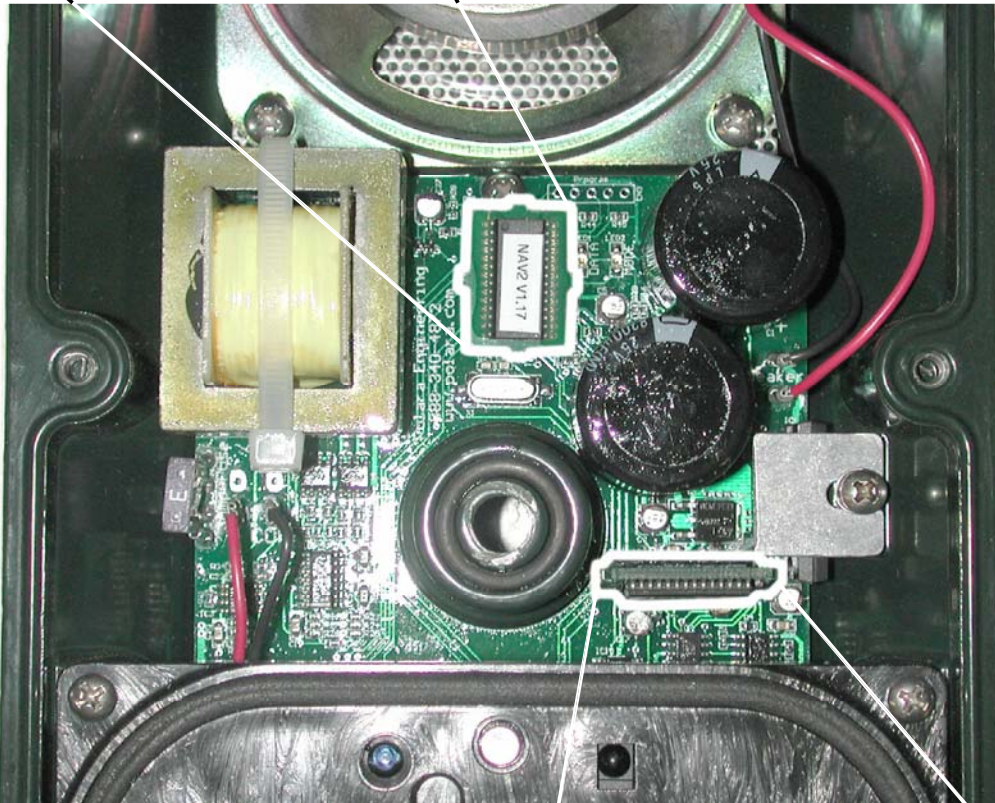

Match polarity dot on Voice Chip with dot on Main PCB (IC should face down).

## Voice Chip:

To remove, pull chip directly out.

To replace, align connector on chip with header on PCB making sure the polarity dot on the chip matches with the polarity dot on the Main PCB.



# CLAM SHELL HAND/MAN DUAL INCANDESCENT LAMP

MOUNTING  
BOLTS

ALL WIRING  
NOT SHOWN.

